

NX Mold Design

The fastest and most complete mold design process

fact sheet

Siemens PLM Software

www.siemens.com/plm

► Summary

NX® Mold Design software delivers a state-of-the-art solution to the shrinking lead times and tighter cost controls facing mold manufacturers today. By combining industry knowledge and best practices with process automation, NX Mold Design streamlines the entire mold development process: from part design to tool assembly layout, tool design and tool validation. NX Mold Design excels at even the most challenging mold designs, providing advanced functionality, step-by-step guidance and associativity with part designs to ensure fast response to design changes and quality molds.

Benefits

- Formalize your design process
- Highly automated core/cavity design
- Capture tooling design knowledge and re-use proven designs
- Comprehensive mold base, molding component system and standard part design
- Fast and efficient design change propagation across entire process (tool design through machining)
- Virtually prototype functional operation of tooling
- Reduce tool design errors
- Collaborate with customers and suppliers
- Standardize the quotation process
- Reduce CNC programming time
- Eliminate conventional drawings – achieve paperless processes
- Centralize and control design information

Key messages

- Embedded process expertise drives productivity and quality with specialized applications and workflows.
- Speed and consistency are achieved with re-usable design standards, custom component libraries and standard component libraries.

Tooling process expertise

Product analysis. Import part geometry and drawings using data translators. Easily model and perform design changes to ensure desired design intent and achieve manufacturability.

Core cavity development. Automate shut-offs and parting of core/cavity based on manufacturability considerations. Design parting surfaces quickly and associatively. Split mold to accommodate complex slider designs. Automatically check the core/cavity design for interferences.

Mold structure. Layout the core, cavity, component systems and mold base for both prototype and production-scale multi-cavity molds. Configure the mold based on libraries of standard parts, component systems and mold bases. Easily configure library content without programming. Design sliders and lifters. Quickly add and trim ejector pins. Insert cooling channels with parametric patterns. Include runners, gates, screws, pins and other common library components.

Detailing. Document the mold design using automated drawing creation with associative hole tables, 3D annotation and hole tolerances. 3D annotation enables paperless communication and manufacturing.

Scalable expert solution. The full range of Siemens PLM Software can provide the most comprehensive solution sets. Full feature and assembly modeling, Xpress review and Strength Wizard are examples of the rich functional capabilities that are included in the Mold Design packages.

Design change and propagation control. Mold development is associative with the product design and updates quickly with design changes. Teamcenter® software keeps the whole team working with the right data.

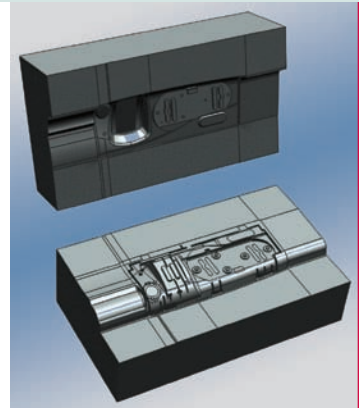

Effective parting surface and patching functions automate the core and cavity design.

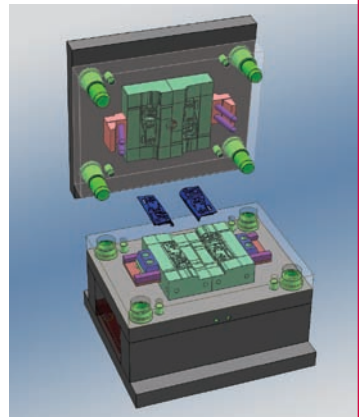

Comprehensive libraries of mold bases, standard parts and component systems accelerate the complete mold assembly.

Key messages continued

Confidence and reputation soar when mold designs are validated and verified.

Processes improve when the solution set is integrated.

Re-use of company standards

Configured inputs. Re-use preconfigured project templates, materials, tools and processes and adapt proven designs to new molds. Accelerate and optimize the mold design process by standardizing processes and components.

Configured outputs. Automate generation of parts lists, drawings, project data structures and NC toolpaths.

Re-usable parts. Build your own re-usable parts and register them in custom libraries. Develop your own re-usable mold base configurations too.

Design validation

Product analysis. Validate part design for manufacturability using wall thickness checking functions, draft analysis and undercut region detection, and radius evaluation.

Tooling analysis. Validate the mold design within the assembly context for proper clearances and reliefs in various positional states. Analyze the electrode requirements. Improve tool longevity with strength analysis and sharp corner detection.

Integrated solution

Design change management. Graphically compare versions of a design for similarities and differences. Swap design versions, control the propagation of change, and efficiently update related features, drawings and toolpaths.

Process and data management. Enable team-oriented design with multiple designers working concurrently on a single mold design. Synchronize and distribute product and process data across tool design and manufacturing teams and re-use proven design practices.

Collaboration. Email lightweight, self-contained viewer files to non-CAD participants in the design process.

Manufacturing integration. Automate manufacturing processes and operation selection via integration of NX Mold Design and NX CAM.

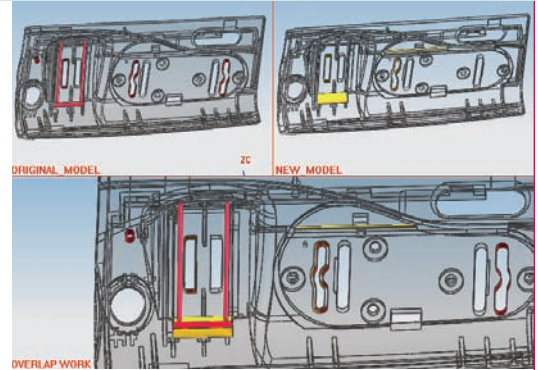

Design change comparison and propagation tools provide high levels of efficiency.

Managed development environment



Work concurrently with team members, search, access and re-use project and process data all within the managed development environment.

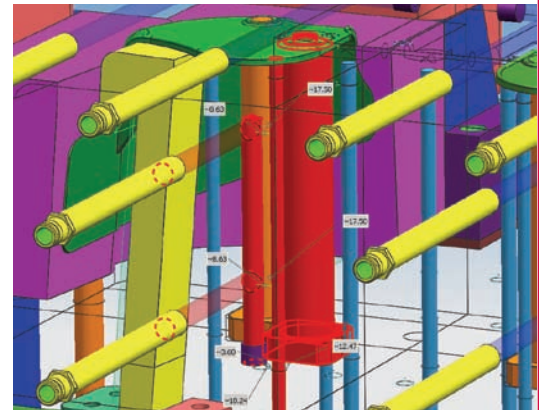

Analyze, visualize and validate clearances between sets of components within the mold design.

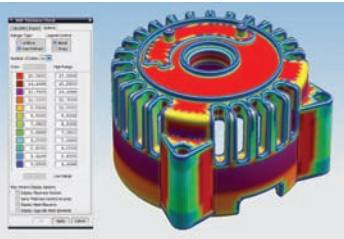

Analyze parts for wall thickness and moldability considerations. Easily visualize results.



NX Mach 3 Mold Design product content

Mold design

- Shrinkage
- Parting line and surfaces
- Shut-off surfaces
- Core/cavity and region split
- Cooling
- Merge cavities
- Runners and gates
- Subinserts and hole charting
- Sliders/lifters
- Template configuration – re-use
- Ejection
- Concept design
- Automated drawing creation and hole charting
- GD&T, 3D annotation, BOM, hole table, wire EDM start hole
- Design change control

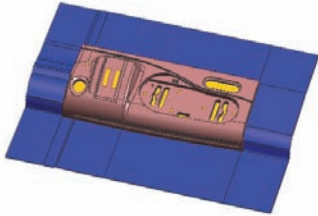

Standard catalog offerings

- Mold bases supported in English and metric units: DME, Futaba, HASCO, LKM, Meusburger, Omni, PCS, Progressive, Rabourdin, Strack, Superior, Universal
- Standard parts and molding systems supported in English and metric units (injection, ejection, cooling, sliders/lifters, guides, locks, dowels, screws, springs, pillars): DME, Futaba, HASCO, National, Meusburger, Omni, Progressive, Rabourdin, Strack, Yates
- Die base management
- Standard part management

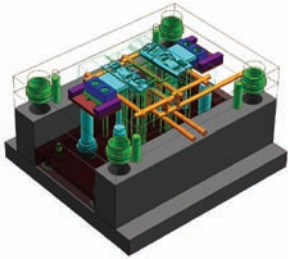

Validation

- Molded part validation
- Parting check
- Product validation
- Tool validation clearance check

Part and assembly modeling

- Solid and feature modeling
- Free form modeling, basic
- Free form modeling, advanced
- DesignLogic
- Straight break sheet metal
- Synchronous Technology
- UDF
- Assembly modeling

Managed development environment

- Vaulting and version management of product and process data
- Web infrastructure for data accessibility
- 2D drawing and 3D part and assembly visualization/markup independent of CAD system
- Supports distributed concurrent team design

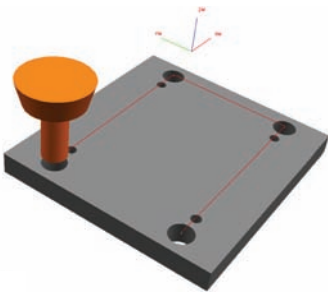

Collaboration

- Package design documents for quoting and design review
- Web publishing
- Early supplier involvement template streamlines work with customer data

Online resources

- Help documentation with tutorials
- Learning Advantage (free and self-paced) - NX Standard Part creation tutorial
- Learning Advantage (free and self-paced) - Mold Base customization guide

Automation

- NX Open and Knowledge Fusion runtime package

Translators

- DXF/DWG
- IGES
- STEP AP 203 and AP 214

Note: all capabilities described above are also available within NX Mach 4 Advanced Mold Manufacturing.

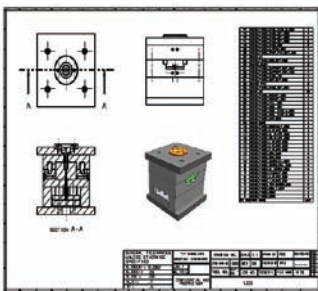

Contact

Siemens PLM Software

Americas 800 498 5351
 Europe 44 (0) 1276 702000
 Asia-Pacific 852 2230 3333

www.siemens.com/plm

SIEMENS